

# SERPAC 053

Electronics Enclosures

NOTES:  
1. WHEN MACHINE OR I PLATES MODIFICATIONS ARE REQUIRED, USE THE CENTER OF THE BOX TO DIMENSION.

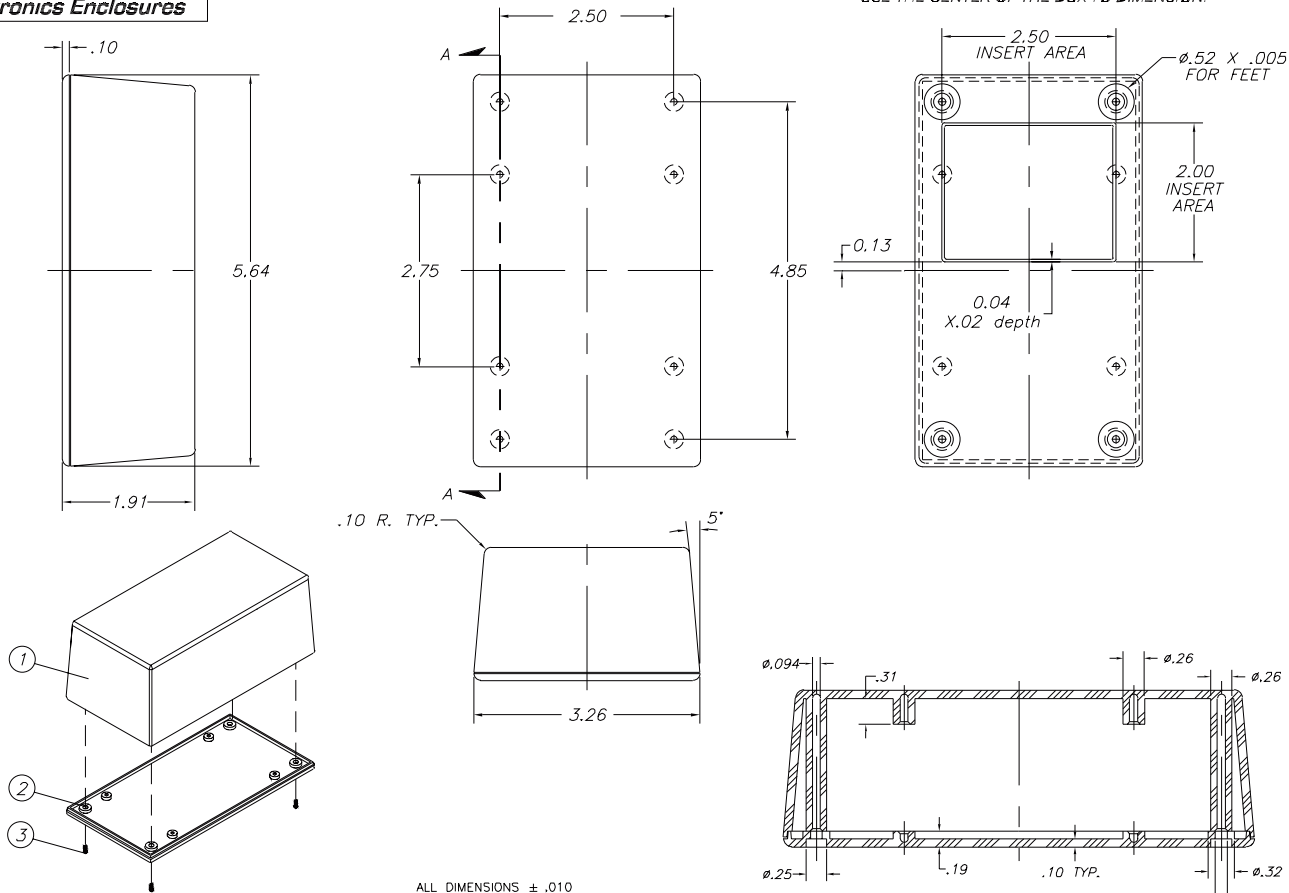

8-17-98.

ALL DIMENSIONS  $\pm .010$

ITEM	PART NO.	DESCRIPTION	ACCESSORIES	
1	53	PLASTIC TOP	PART NO.	DESCRIPTION
2	05	PLASTIC BOTTOM	51	FEET
3	6005	SCREWS (4)	360	PROTOTYPE GRID BOARD (HORIZ.)
			450	PROTOTYPE CLAD BOARD (HORIZ.)

SECTION A-A

# SERPAC 053-1

Electronics Enclosures

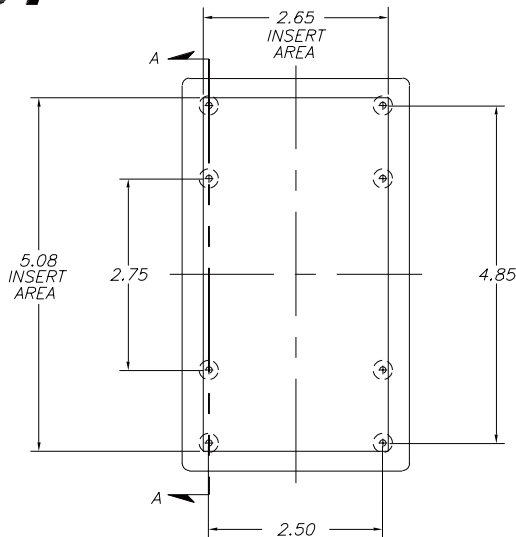
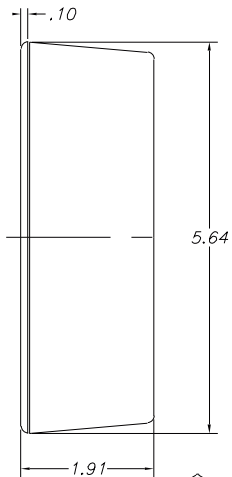

NOTES:  
1. WHEN MACHINE OR I PLATES MODIFICATIONS ARE REQUIRED, USE THE CENTER OF THE BOX TO DIMENSION.

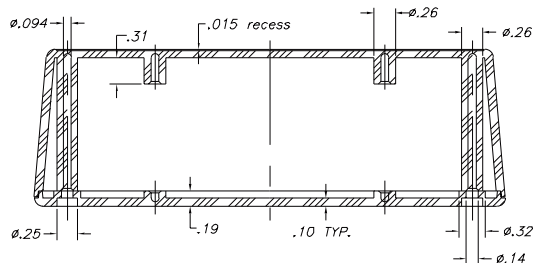
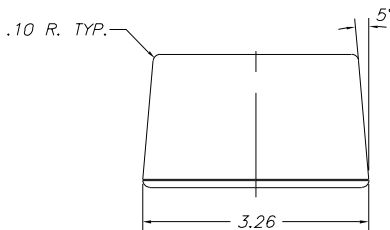
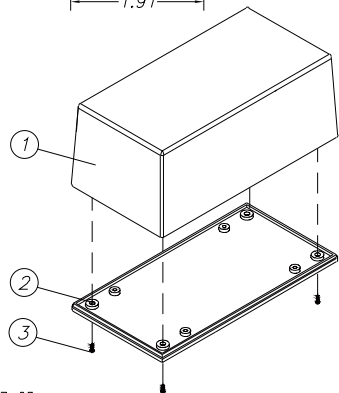
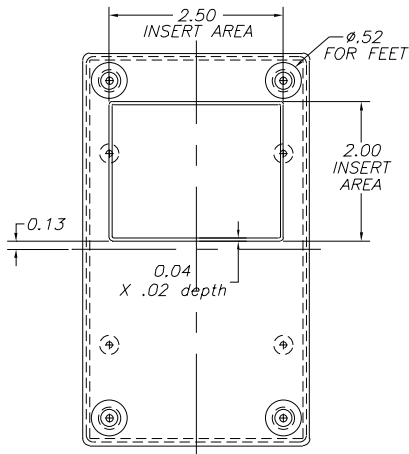

SECTION A-A

8-17-98.

ALL DIMENSIONS ± .010

ITEM	PART NO.	DESCRIPTION	PART NO.	ACCESSORIES DESCRIPTION
1	531	PLASTIC TOP	51	FEET
2	05	PLASTIC BOTTOM	360	PROTOTYPE GRID BOARD (HORIZ.)
3	6005	SCREWS (4)	450	PROTOTYPE CLAD BOARD (HORIZ.)

619 Commercial Ave. Covina, CA 91723

(626) 331-0517 Fax (626) 331-8584 <http://www.serpac.com>